



500 kV Transmission line

CHOM BUNG (CBG) – SAI NOI (SNO) No. 1, 2 and 3

CHOM BUNG (CBG) – PHA CHI (PH2)

Trip, Recloser in “OFF” position

Best Practices in Power System Operation & Grid Management

7th April 2026



EGAT



Mr. KRICHAKORN SUTTHASUPA
Engineer Level 7
Power System Control and Operation Division
Electricity Generating Authority of Thailand



Work Experience

- 2013 – 2018** Combined cycle power plant operator
- 2018 – 2022** Hydro power plant operator
- 2022 – Present** System operator



Presentation Outline



Introduction of transmission system tie-line



System condition before fault event



System Condition after fault event



Post-incident actions



Restore the system to normal operation





Introduction of transmission system tie-line

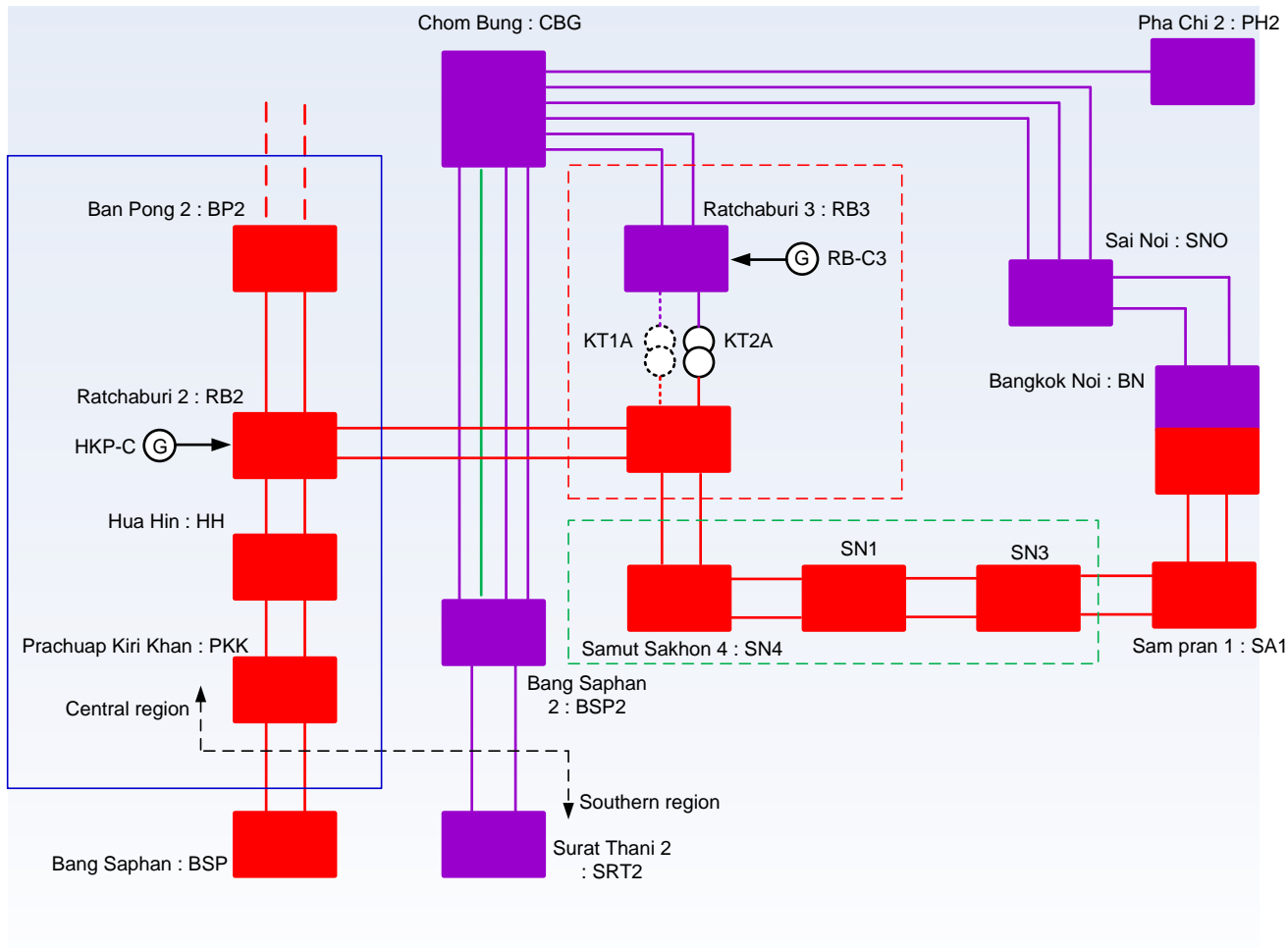

500 kV Chom Bung substation connected with transmission line 500 kV CBG – SNO for 3 circuits, 500 kV CBG – PH2 and 500 kV CBG – RB3 for 2 circuits which received power from transformer 500/230 kV KT2A.

Power transmission from central region to southern region of Thailand through transmission line 500 kV CBG – BSP2 for 4 circuits (No. 2 switch off for reduce voltage) and 230 kV BSP – PKK for 2 circuits.





System condition before fault event

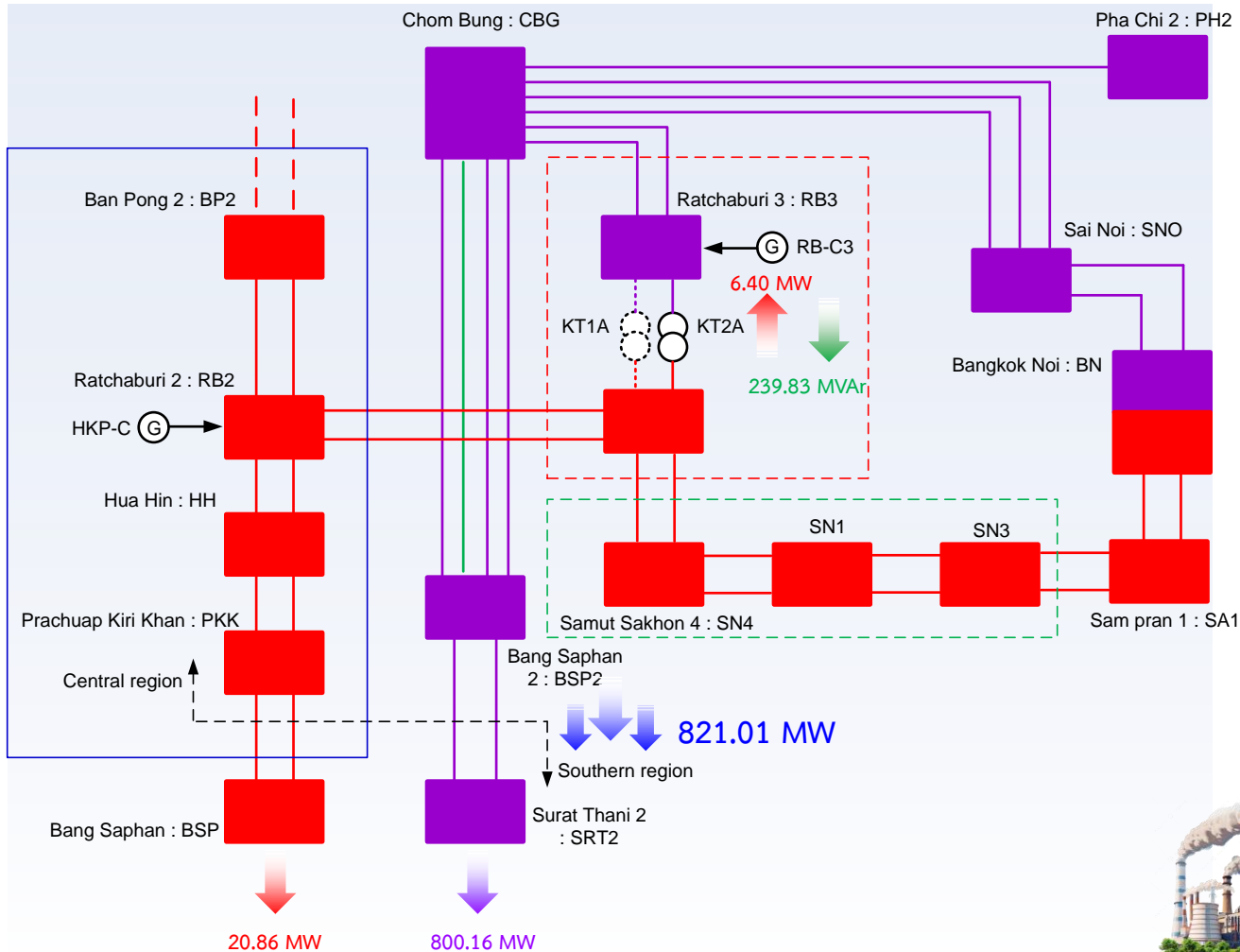

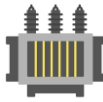
- ❑ Transformer 500/230 kV RB3 KT2A supply load for 239.93 MVA (Rated 750 MVA). 
- ❑ Transformer 500/230 kV RB3 KT1A shutdown for Major overhaul OLTC.
- ❑ Power flow tie - line (Central - Southern region) ~ 821.0 MW.

South region power plant	Generated	Shutdown
Chana block 1		✓
Chana block 2 unit 1	✓	
Chana block 2 unit 2	✓	
Kanom block 2 unit 1	✓	
Kanom block 2 unit 2		✓





Fault events timeline



02:39 a.m. – 500 kV CBG – SNO No. 3 Trip recloser operate.
02:47 a.m. – 500 kV CBG – SNO No. 3 Trip recloser in “OFF” position.



04:05 a.m. – 500 kV CBG – PH2 Trip recloser operate one sided at CBG.
04:08 a.m. – 500 kV CBG – PH2 Trip one sided at CBG recloser in “OFF” position.



04:15 a.m. – 500 kV CBG – SNO No. 2 Trip recloser in “OFF” position.



04:16 a.m. – 500 kV CBG – SNO No. 1 Trip recloser in “OFF” position.



Why recloser in “OFF” position ?

For mitigate the effect of switching overvoltage as this region serves many industrial customers.





System condition after fault event

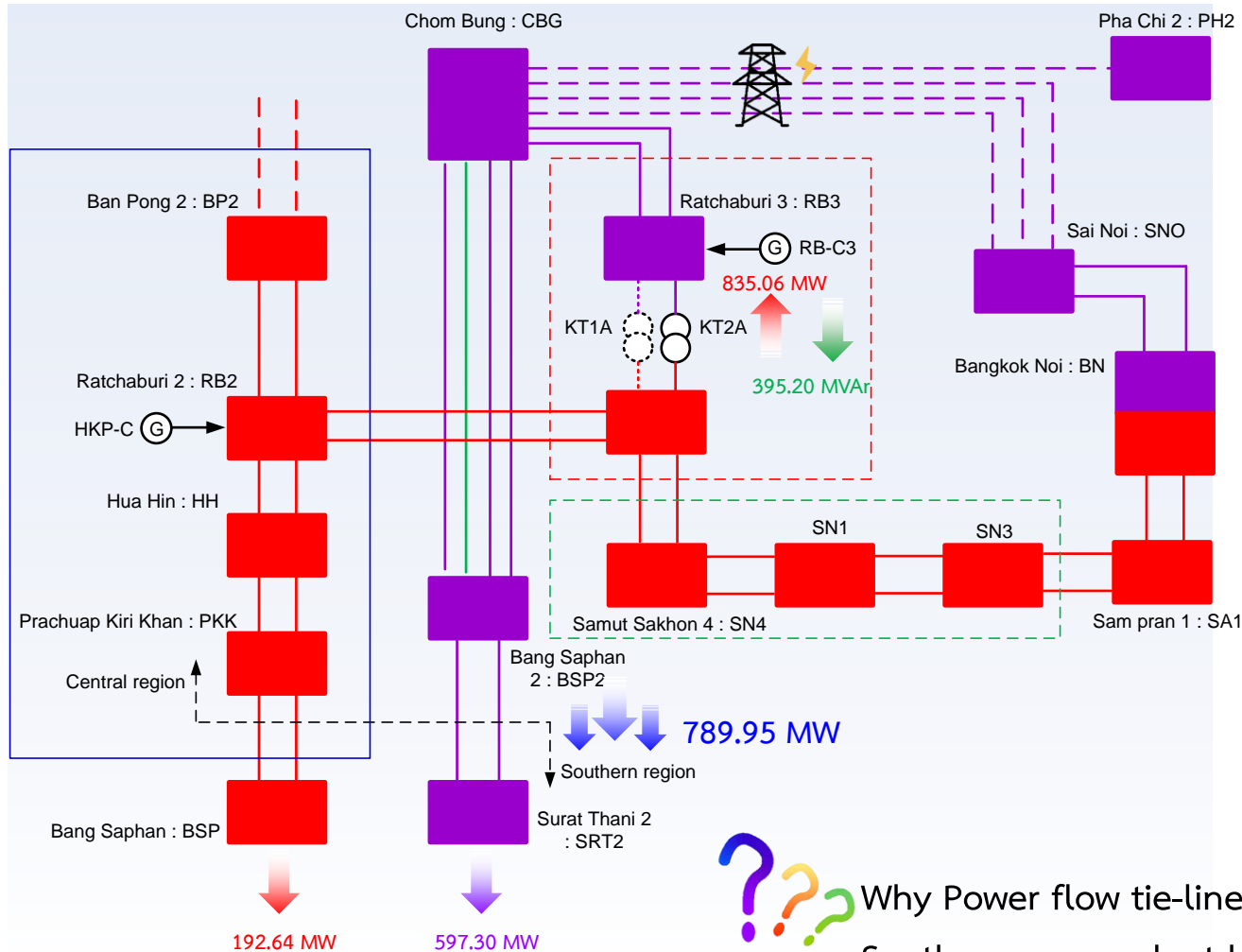

Transformer 500/230 kV RB3 KT2A overload with power flow 923.9 MVA (123.2 % overload).

Power flow tie - line (Central - Southern region) ~ 790.0 MW (Control not more than 750 MW without 500 kV transmission line)

In Worst case scenario transformer 500/230 kV RB3 KT2A Trip. As though not have 500 kV transmission line from CBG-Sub to STR2-Sub.



Why Power flow tie-line decreased significantly ?

Southern power plant both of Kanom and Chana combined cycle power plant increased power output.







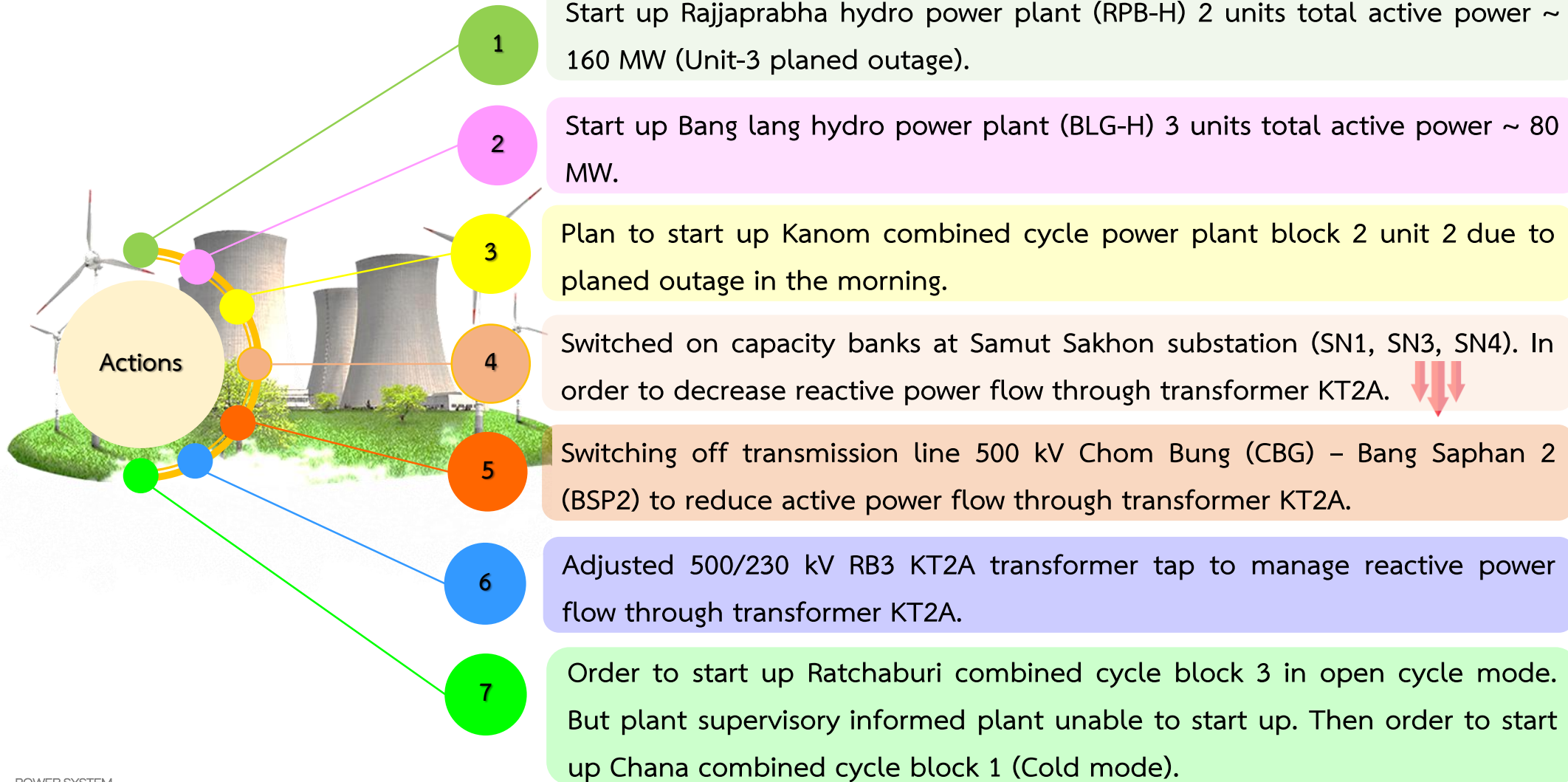



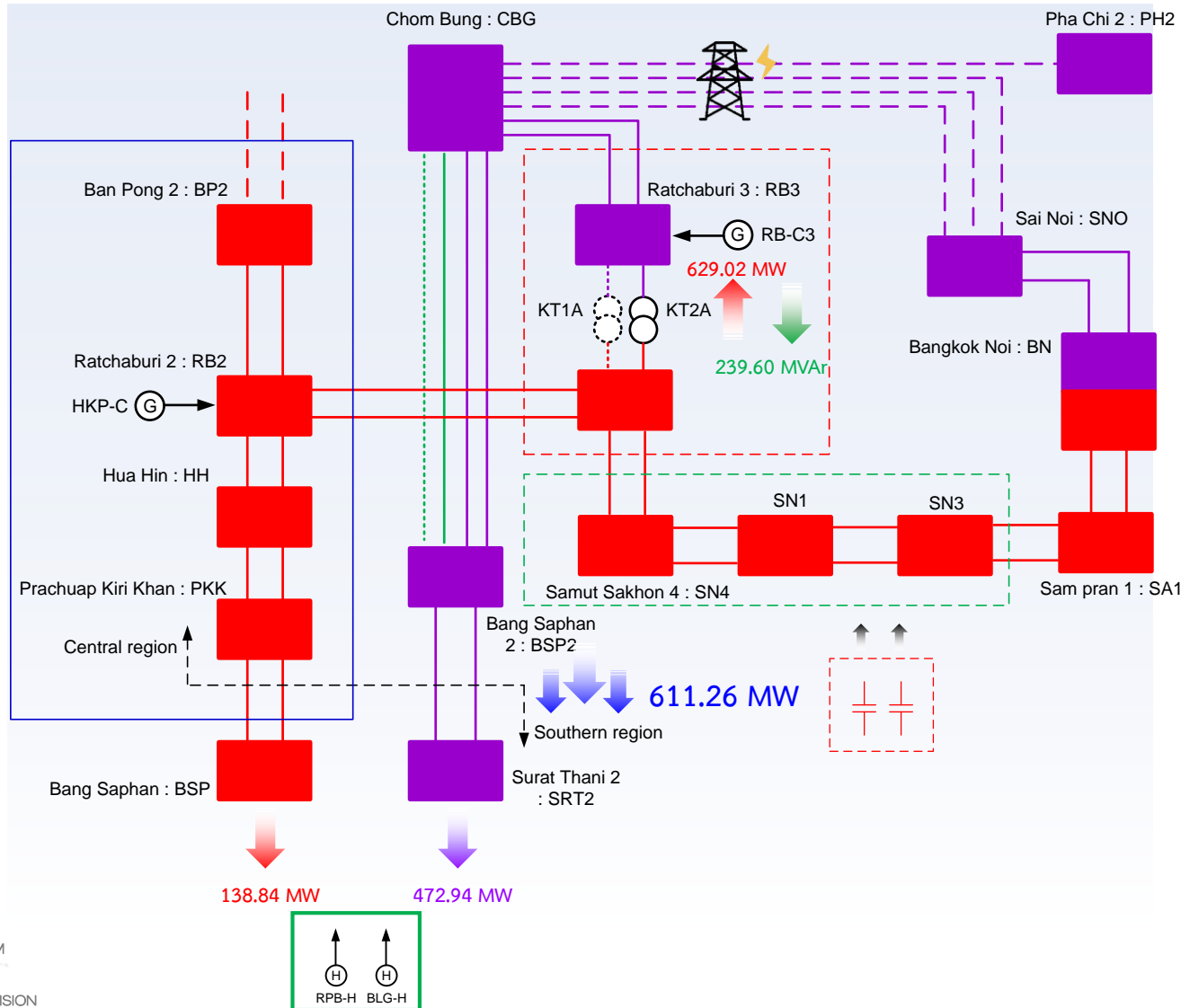

Post-incident actions





System condition after post-incident actions



-  RB3 KT2A Power flow  923.9 – 673.1 MVA
-  Power flow tie – line  821.0 – 611.3 MW
-  500 kV BSP2 – CBG  597.3 – 472.9 MW
-  230 kV BSP – PKK  192.6 – 138.84 MW





Restore the system to normal operation

- 08:12, 08:18 a.m. Reconnected 500 kV CBG – SNO No. 1, 2
- 08:22 a.m. Chana combined cycle GT11 synchronized generator to grid.
- 11:14 a.m. Reconnected 500 kV CBG – PH2
- 12:01 a.m. Chana combined cycle ST10 synchronized generator to grid.
- 17:02 p.m. Reconnected 500 kV CBG – SNO No. 3



Cause : High pollution and relative humidity result to

- 500 kV CBG – SNO No. 2. Insulator flashover on phase C.
- 500 kV CBG – SNO No. 3. Insulator flashover on phase A.
- 500 kV CBG – PH2 Insulator flashover on phase A.



Q&A





EGAT